



## 19.6W Power over Ethernet Adapter DC Input Single Port Injector



### Features

- Detection and Classification per IEEE802.3af
- Diagnostic LEDs
- Non-Vented Case
- DC Input Voltage 18-72VDC
- Full Protection OCP, OVP
- Gigabit Compatible
- 1 Year Warranty
- Lowest cost DC Input Power Injector

### Applications

- IP Telephones
- Wireless Network Access Points
- Blue Tooth Access Point
- Security Cameras
- IP Print Servers

### Safety Approvals

- CE

### Mechanical Characteristics

- Length: 140mm (5.51in)
- Width: 65mm (2.55in)
- Height: 36mm (1.42in)
- Weight: 0.2Kg (0.44lb.)

### Output Specifications

Model	DC Output Voltage	Load		Regulation	
		Min.	Max.	Line	Load
POE20D-1AF-R <sup>1</sup>	56V	0A	0.35A	54-57Vdc under all conditions	

Notes: (1) Consult factory for availability

Phihong is not responsible for any error, and reserves the right to make changes without notice. Please visit our website at [www.phihong.com](http://www.phihong.com) for the most up-to-date specifications and contact information.

**INPUT:****DC Input Voltage Range**

18 to 72VDC

**DC Input Current**

1.5A for 18V DC and maximum load

**OUTPUT:****Total Output Power**

19.6W at 56VDC

**DC Offset**

No data degradation with DC imbalance 18mA

**Efficiency**

80% at maximum load (&gt;36 to 72VDC)

75% at maximum load(18 to &lt;36VDC)

**Ripple and Regulation**

100mV maximum at ambient 25°C

**Transient O/P Voltage Protection**

60V maximum at switch on and off

**ENVIRONMENTAL:****Temperature**

Operation -20 to +50°C

Non-operation -25 to +85°C

Humidity 5 to 90%

**EMC**

Complies with FCC Part 15 Class B

Complies with EN55032 Class B

**Isolation Test**

Primary to Secondary: 2121VDC for 1 minute, 10mA

Primary to Field Ground: 2121VDC for 1 minute, 10mA

Output to Field Ground: 2121VDC for 1 minute, 10mA

**Immunity**

ESD: EN61000-4-2. Level 3

RS: EN61000-4-3. Level 3

EFT: EN61000-4-4. Level 2

Surge: EN61000-4-5. Level 3

CS: EN61000-4-6. Level 3

Voltage Dips EN61000-4-11

Harmonic: EN61000-3-2

**Insulation Resistance**

Primary to Secondary: &gt;10M OHM 500VDC

Primary to Field Ground: &gt;10M OHM 500VDC

**FEATURES:****Over Voltage/Current, Short Circuit Protection**

Outputs equipped with short circuit protection and overload protection as per 802.3af specification

The output can be shorted permanently without damage

**Indicators**

Green LED 1: Input power “ON”

Red LED: Fault detected

Green LED 2: Valid IEEE802.3af load detected and connected

**Input Connector**

– Anytek OQ0355510000G

Mate – Anytek TJ0350520000G or

TJ035152000G

Anytek is part of Giga-Way Technology Corp

**Output Connection**

+pins 3, 6

-pins 1, 2

**Warranty**

1 Year

**Dimension Diagram Unit: mm (inch)**

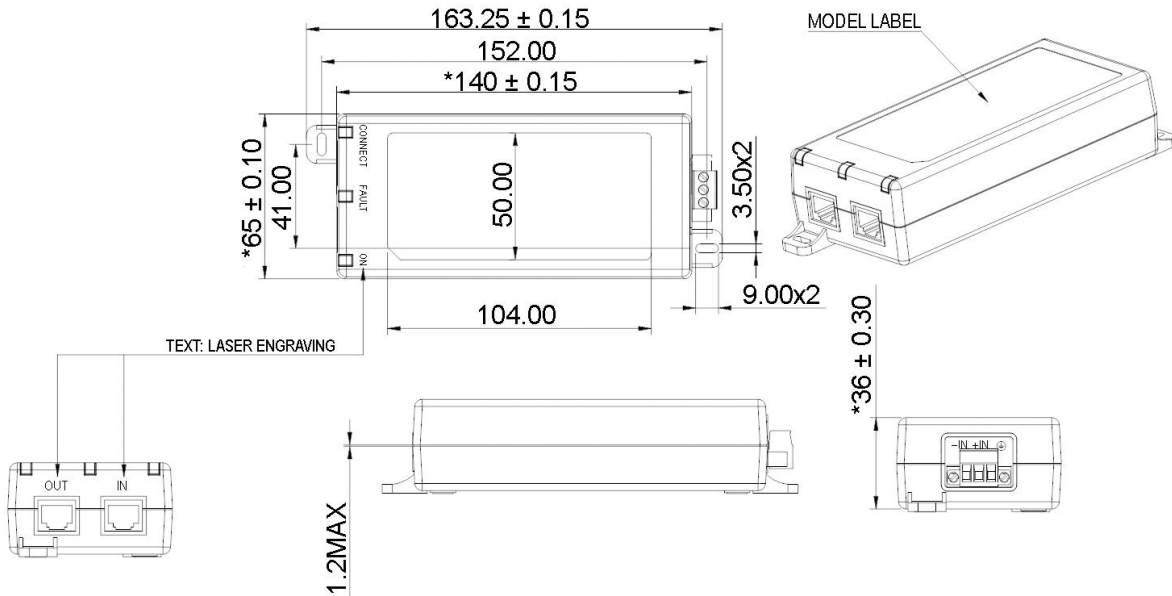

**Gigabit Power Injector Block Diagram**

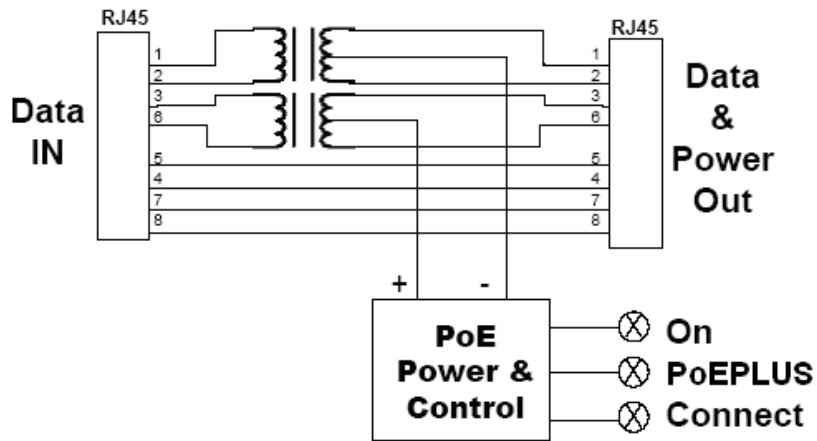

**Description of LED Functions for Gigabit Power Injector**

**Power-up Sequence:**

Upon power-up, all 3 LEDs will light for 2 seconds, as part of the self-test for the internal microprocessor software. After the end of the 2 seconds, the "ON" LED will illuminate green, signifying that the DC output voltage is available for powering a compliant load (to the 802.3af PoE standards).

### **Detection Sequence:**

Once a compliant load is attached to the output RJ45 connector, the green "CONNECT" LED will illuminate.

Should the load be non-compliant then the LEDs will blink a code signifying the cause for non-detection.

### **Detection Failure Codes:**

1. Incorrect resistive signature – The green "CONNECT" and red "FAULT" LEDs will blink 3 times.
2. Incorrect capacitive signature – The green "ON" LED will blink 3 times.
3. Incorrect Voffset – The green "CONNECT" and green "ON" LEDs will blink 3 times.
4. Unstable current measurement – The green "ON" LED will blink 3 times
5. Low voltage sensed during detection (overload) – The red "FAULT" LED will blink 3 times

After the LEDs blink 3 times the Power Injector will continue to try to detect a valid load. Therefore, until the correct load is applied, the LEDs will continue to blink. If there is an open circuit connected to the output RJ45 then the LEDs will not blink but the Power Injector will continue to try to detect a valid load.

### **Fault Sequence:**

Should there be a fault such as an overload or short circuit then the red "FAULT" LED will illuminate. The red "FAULT" LED will illuminate for 2 seconds and then go off as the power supply tries to redetect a valid load. If there is a problem in detecting, the LED will indicate what is wrong with the load as per the codes in the section above.

**Supplier's Declaration of Conformity**  
**47 CFR § 2.1077 Compliance Information**

Phihong USA Corporation  
47800 Fremont Boulevard  
Fremont, CA 94538  
Telephone: (510) 445-0100  
[www.phihong.com](http://www.phihong.com)

The model has/The models in this product series have been tested and found to comply with the limits for a Class B digital device, pursuant to part 15 of the FCC Rules. These limits are designed to provide reasonable protection against harmful interference in a residential installation. This equipment generates, uses and can radiate radio frequency energy and, if not installed and used in accordance with the instructions, may cause harmful interference to radio communications. However, there is no guarantee that interference will not occur in a particular installation. If this equipment does cause harmful interference to radio or television reception, which can be determined by turning the equipment off and on, the user is encouraged to try to correct the interference by one or more of the following measures:

- Reorient or relocate the receiving antenna.
- Increase the separation between the equipment and receiver.
- Connect the equipment into an outlet on a circuit different from that to which the receiver is connected.
- Consult the dealer or an experienced radio/TV technician for help.

Changes or modifications to equipment not expressly approved by PHIHONG could void the user's authority to operate the equipment.